

Hardware Installation Manual

Modular Silicon Expansion Valve (MSEV)
High Capacity Modular Silicon Expansion Valve (HC-MSEV)
Very High Capacity Modular Silicon Expansion Valve (VHC-MSEV)
Universal SuperHeat Controller/Sensor (USHX)

Revision 1.7



DunAn Microstaq, Inc.
4120 Freidrich Lane, Suite 225
Austin, Texas 78744 United States
(512) 628-2890
www.dmq-us.com

Published: July 2019
©2019

This manual is applicable to the following MSEV model numbers:

- A12V-U112
- A12V-U116
- A12V-U118
- A12V-U120
- A12V-U124
- A12V-C112
- A12V-C116
- A12V-C119
- A12V-C122
- A12V-C124
- A12V-C127
- A12V-C132
- A12V-C134
- A24V-U112
- A24V-U116
- A24V-U118
- A24V-U120
- A24V-U124
- A24V-C112
- A24V-C116
- A24V-C119
- A24V-C122
- A24V-C124
- A24V-C127
- A24V-C132
- A24V-C134

This manual is applicable to the following HC-MSEV model numbers:

- A12V-C332
- A12V-C338
- A12V-C343
- A12V-C348
- A12V-C352
- A12V-C355
- A12V-C358
- A24V-C332
- A24V-C338
- A24V-C343
- A24V-C348
- A24V-C352
- A24V-C355
- A24V-C358

This manual is applicable to the following VHC-MSEV model numbers:

- A12V-C6612
- A12V-C6650
- A12V-C6715
- A12V-C6773
- A12V-C6799
- A24V-C6612
- A24V-C6650
- A24V-C6715
- A24V-C6773
- A24V-C6799

This manual is applicable to the following USHX model numbers:

- USHC-G1.3b-BAAAXXX
- USHS-G1.3b-BAAAXXX

Additional Product Markings for USHC-G1.3b and USHS-G1.3b

- Operating Control
- Independently Mounted
- Pollution Degree 2
- Impulse Voltage: 300 V
- SELV Circuit Voltage I/O
- Operating Pressure: 21 to 240 psia
- Proof Pressure: 600 psi
- Burst Pressure: 1500 psi

Table of Contents

| | | |
|----------|---|-----------|
| 1 | Before You Begin | 1 |
| 1.1 | About This Manual | 1 |
| 1.2 | Document Conventions | 1 |
| 1.3 | Acronyms | 1 |
| 1.4 | About the MSEV Series and the USHX | 2 |
| 2 | Mechanical Installation | 4 |
| 2.1 | Installing a MSEV Series Valve | 4 |
| 2.2 | Installing the USHX..... | 6 |
| 3 | Electrical Wiring | 10 |
| 3.1 | Single USHC and MSEV Series Valve or Single USHS..... | 10 |
| 3.2 | Multiple USHCs and MSEV Series Valves or Multiple USHSs | 12 |
| 4 | Troubleshooting | 17 |

1 Before You Begin

1.1 About This Manual

The following table shows a summary of the sections in this document and their descriptions.



Table 1-1 Descriptions of the Sections in the Document

| Section Title | Description |
|--------------------------------|---|
| <i>Before You Begin</i> | This section provides preliminary information about the products. |
| <i>Mechanical Installation</i> | This section provides instructions about the mechanical installation of the MSEV series and the USHX in the system. |
| <i>Electrical Wiring</i> | This section provides instructions about the electrical wiring of the MSEV series valve and the USHX. |
| <i>Troubleshooting</i> | This section provides solutions to potential problems. |

1.2 Document Conventions

The following table shows a list of symbols found in this document and their descriptions.

Table 1-2 Descriptions of Symbols in the Document

| Symbol | Description |
|--|--|
|  | <i>WARNINGS</i> indicate that the action you are taking could either cause injury to yourself or could harm your products and systems. |
|  | <i>IMPORTANT NOTES</i> appear in the text to indicate additional information that should be noted. |

1.3 Acronyms

The following table shows a list of acronyms used in this document.

Table 1-3 Acronyms and Abbreviations in the Document

| Acronym | Description |
|-------------|---|
| MSEV | Modular Silicon Expansion Valve |
| HC-MSEV | High Capacity Modular Silicon Expansion Valve |
| VHC-MSEV | Very High Capacity Modular Silicon Expansion Valve |
| MSEV Series | MSEV, HC-MSEV and VHC-MSEV |
| MEMS | Microelectromechanical Systems |
| EEV | Electronic Expansion Valve |
| TXV | Thermostatic Expansion Valve |
| HVAC/R | Heating, Ventilation, Air Conditioning, and Refrigeration |
| USHX | Universal SuperHeat Controller or Sensor |
| USHC | Universal SuperHeat Controller |
| USHS | Universal SuperHeat Sensor |
| ID / OD | Inner Diameter / Outer Diameter |
| AC / DC | Alternating Current / Direct Current |

1.4 About the MSEV Series and the USHX

The MSEV series valves **Modular Silicon Expansion Valve (MSEV)**, **High Capacity Modular Silicon Expansion Valve (HC-MSEV)** and the **Very High Capacity Modular Silicon Expansion Valve (VHC-MSEV)**, shown in Error! Reference source not found., are two-stage proportional control expansion valves that utilize DunAn Microstaq's patented silQflo® technology. The silQflo is a microelectromechanical systems (MEMS) microvalve technology used to provide precise mass flow control for industry-standard HVAC and refrigeration applications. The MSEV consists of a MEMS pilot valve which acts as a first stage valve that applies varying fractions of fluid line pressure onto the second stage spool valve according to the command signal provided by the Universal SuperHeat Controller (USHC). The MSEV is installed at the inlet of the evaporator.

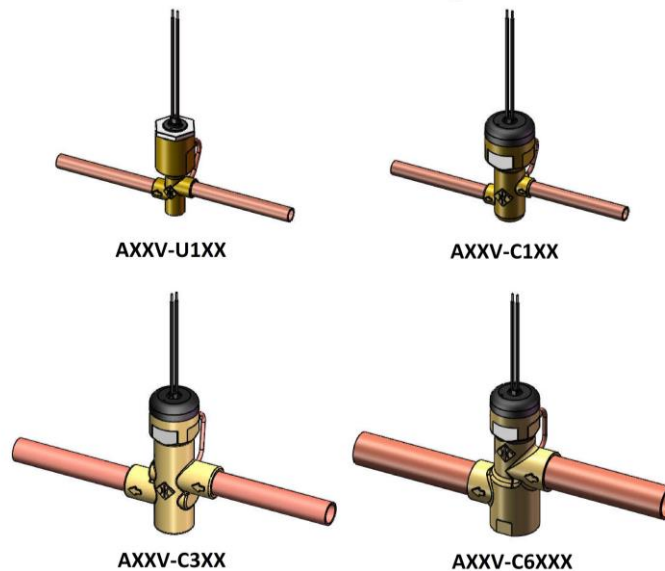

Figure 1-1 MSEV Family

The **Universal SuperHeat Controller/Sensor (USHX)**, shown in **Figure 1-2**, is offered either as a:

- Universal SuperHeat **Controller** (USHC): To drive and control a MSEV series valve.
- Universal SuperHeat **Sensor** (USHS): To measure and report temperature, pressure, and superheat values.

The USHX consists of an internal MEMS pressure sensor and a processing unit. It uses a wiring harness, shown in **Figure 1-3**, to measure the evaporator temperature and control a MSEV series valve. The USHX is installed at the outlet of the evaporator; it mounts on a 1/4" access fitting and utilizes the Modbus RTU communication protocol for user interaction.



Figure 1-3 USHX



Figure 1-2 USHX Wiring Harness

The USHX and its wiring harness pin assignments are shown in **Table 1-4**.

Table 1-4 USHX and Wiring Harness Pin Assignments

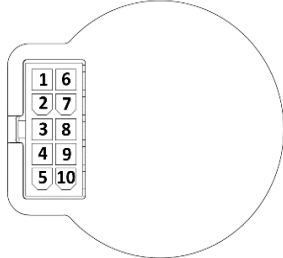
| <div style="display: flex; justify-content: space-between; align-items: center;"> <div style="flex: 1;"> <p>USHX-G1.3b Series Model Numbers</p> <ul style="list-style-type: none"> • USHC-G1.3b-BAAAXXX • USHS-G1.3b-BAAAXXX </div> <div style="flex: 1; text-align: center;">  </div> </div> | | | | |
|---|----------|--|-------------------------|----------------------|
| Pin Number | Pin Name | Pin Function | Type of Wire | Wiring Harness Model |
| | | | | WH-USHX-AX |
| Pin 1 | AC2 | Power Input | Red, 18 AWG | ✓ |
| Pin 6 | AC1 | Power Input | Black, 18 AWG | ✓ |
| Pin 3 | DATA- | RS485- Communication | Black, 24 AWG, Shielded | ✓ |
| Pin 4 | DATA+ | RS485+ Communication | Red, 24 AWG, Shielded | ✓ |
| Pin 2 | DGND | Digital Signal Ground and Thermistor Signal Ground | Green, 22 AWG | ✓ |
| Pin 9 | SENS | Thermistor Power | Black, 24 AWG | ✓ |
| Pin 7 | PWM+ | PWM Output | White, 18 AWG | ✓ |
| Pin 8 | PWM- | PWM Output | White, 18 AWG | ✓ |
| Pin 5 | GPB | General Purpose – Not Utilized | Brown, 20 AWG | ✓ |
| Pin 10 | GPA | General Purpose – Not Utilized | Purple, 20 AWG | ✓ |

Note:

✓ = Available

2 Mechanical Installation

This section describes the mechanical installation of a MSEV series valve and USHX. **Figure 2-1** below shows an example of a typical system where the MSEV series valve and USHX devices would be integrated into. Like conventional thermostatic expansion valves (TXVs) or electronic expansion valves (EEVs), the MSEV series valve is installed at the inlet of the evaporator. The USHC, which drives and controls the MSEV series valve, is installed at the outlet of the evaporator, in place of the TXV bulb or EEV controller sensing device. The MSEV series and USHC are connected together by a wiring harness. A thermistor at the outlet of the evaporator measures the temperature, and the USHC is powered by the Class 2 power source.



Do NOT turn the power source ON until installation of MSEV series valve, USHX and wiring harness is complete. For the user's own safety, **only** Class 2 power source should be used to power the MSEV series and USHX devices.

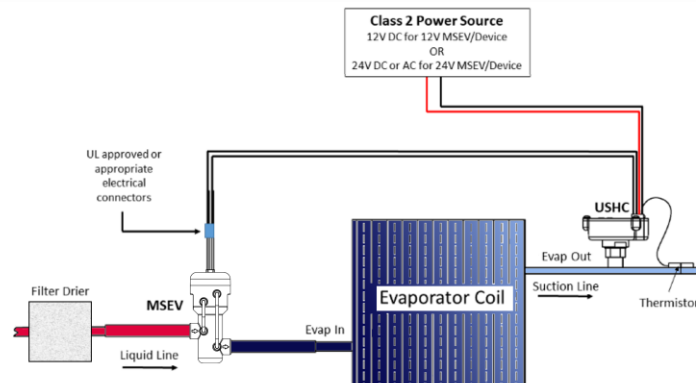

Figure 2-1 MSEV series valve and USHC installation schematic

2.1 Installing a MSEV Series Valve

To install the MSEV series valve, complete the following steps:

1. Pump down and recover any residual refrigerant from the system.
2. Remove the current TXV and its bulb or EEV and its controller by cutting. Take care to minimize the risk of introducing contaminants into the system when removing the existing valve.
3. Before continuing, clean the copper connections of the MSEV series valve. The OD of the MSEV, HC-MSEV and VHC-MSEV copper tubes are 3/8", 5/8" and 3/4" respectively.



Do NOT reduce the length of the copper tubes when brazing. Flare fittings should be used if the copper tubes length is reduced.

4. Position the valve as displayed in **Figure 2-2** and ensure the arrow mark aligns with the direction of fluid flow. The blue arrows show which way fluid is supposed to flow through the valve. Also ensure that the MSEV series valve is installed in an upwards orientation or at any angle less than 90° in either direction (represented by the curved green arrows).



The MSEV series valve cannot be installed in a downwards orientation (shown in curved red arrows). It will not function as intended if installed in this way.

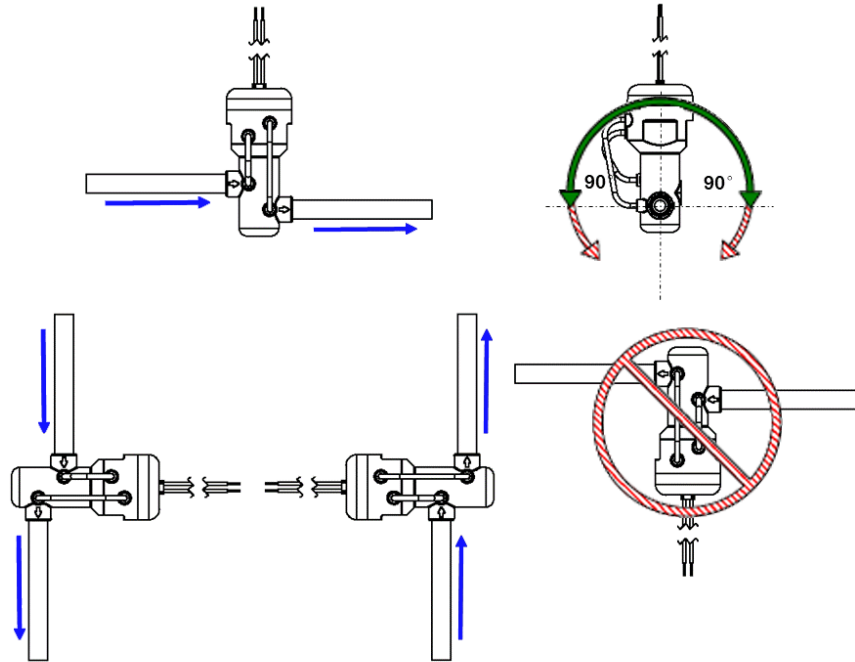

Figure 2-2: MSEV series valve installation orientation

5. Wrap the valve body with a wet cloth before brazing.
6. Connect the MSEV series valve to the inlet of the evaporator by brazing. Allow the valve to air-cool after brazing.



While brazing, direct heat away from the valve body. Ensure that the temperature of the valve body does not exceed 221°F (105°C).

7. It is mandatory to install a brand-new filter drier at the inlet of the MSEV series valve as indicated in Figure 2-1. It can be installed at about 6" away from the valve. The MSEV series valve must be protected against contaminants to ensure its optimal operation.



DMQ highly recommends using a filter drier with a 20 micron filtration rating.

8. The MSEV series valve installation process is now complete.

2.2 Installing the USHX

To install the USHX, complete the following steps:

1. Pump down and recover any residual refrigerant from the system. This may have already been done if a MSEV series valve was installed before this step.
2. Obtain any $\frac{1}{4}$ " access fitting that is compatible with the system. In this section, a $\frac{1}{4}$ " access fitting with a $\frac{3}{16}$ " OD extended tube is used as an example to demonstrate the installation process.
3. See **Figure 2-3** and **Figure 2-4** below for the proper orientation of the USHX. When installing the device on a horizontal copper line as shown in **Figure 2-3**, the USHX can only be installed up to a 45° angle from the vertical axis in either direction (represented by the curved green arrows). When installing the device on a vertical copper line as shown in **Figure 2-4**, the USHX cannot be installed at a downward angle (represented by the red arrow).

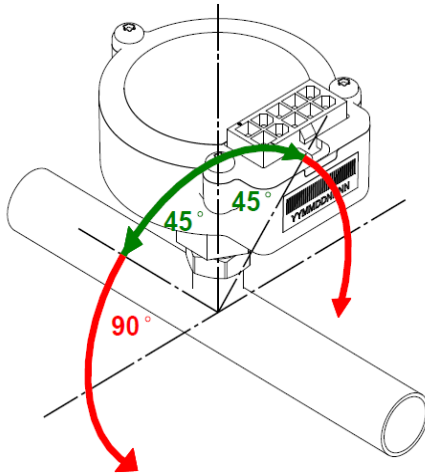

Figure 2-3: USHX installation orientation on a horizontal copper line

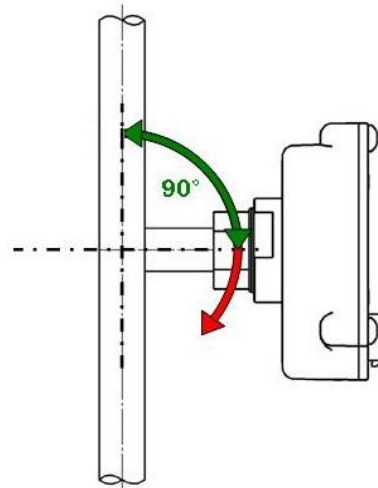

Figure 2-4: USHX installation orientation on a vertical copper line

4. Drill a hole into the copper line that extended tubes may fit in to. The location of this hole should be about 6" away from the outlet of the evaporator.



Care must be taken to not introduce copper shavings into the copper line while the hole is being drilled.

5. Remove the valve core of the access fitting before brazing.
6. Braze the access fitting to the copper line and allow it to air-cool after brazing.
7. Place the valve core back onto the access fitting and tighten the connection. This step completes the installation of the $\frac{1}{4}$ " access fitting. The final result should look similar to what is shown below in **Figure 2-5**.

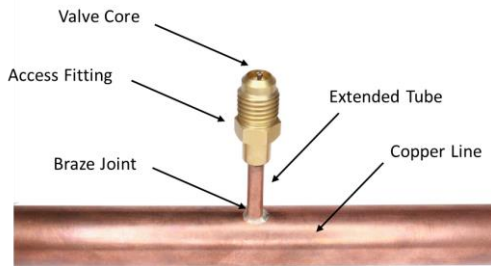

Figure 2-5: Brazed access fitting

8. Mount the USHX onto the access fitting. First, turn the USHX clockwise by hand until some resistance is observed. Then, use a torque wrench to tighten the USHX to 70 in-lb as shown in **Figure 2-6**.

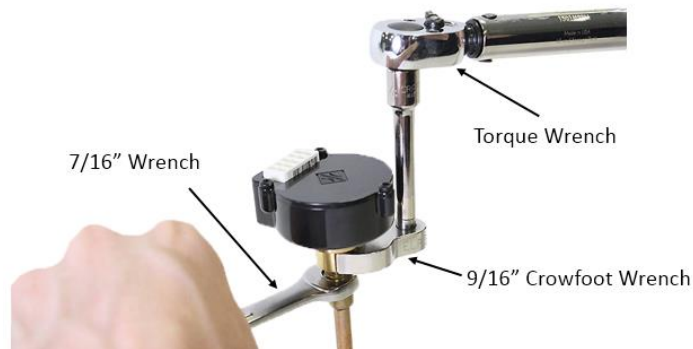

Figure 2-6 USHX Installation with Torque Wrench (70 in-lb)



When torque wrench not available use 7/16" and 9/16" wrenches to tighten the USHX as shown in **Figure 2-7**. Using two wrenches will ensure that the brazed joint is not damaged during tightening.



Do NOT turn the power source ON during the installation of the wiring harness.

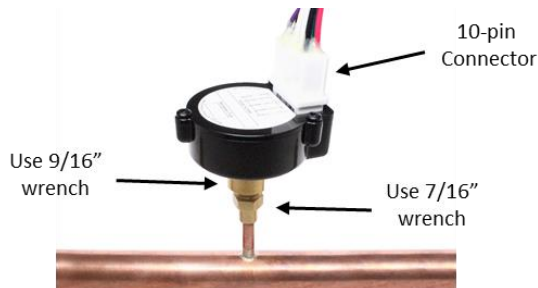

Figure 2-7 Installed USHX with attached 10-pin wiring harness

9. Attach the wiring harness (10-pin connector) to the USHX as shown in **Figure 2-7**.



If the USHX is located in a wet or potentially wet environment, apply silicone grease inside the 10-pin connector of the wiring harness.

- 10.** Install the thermistor at the outlet of the evaporator and close to the access fitting using a zip tie, as shown below in **Figure 2-8**. The thermistor should be located at either the 10 o'clock or 2 o'clock position only.

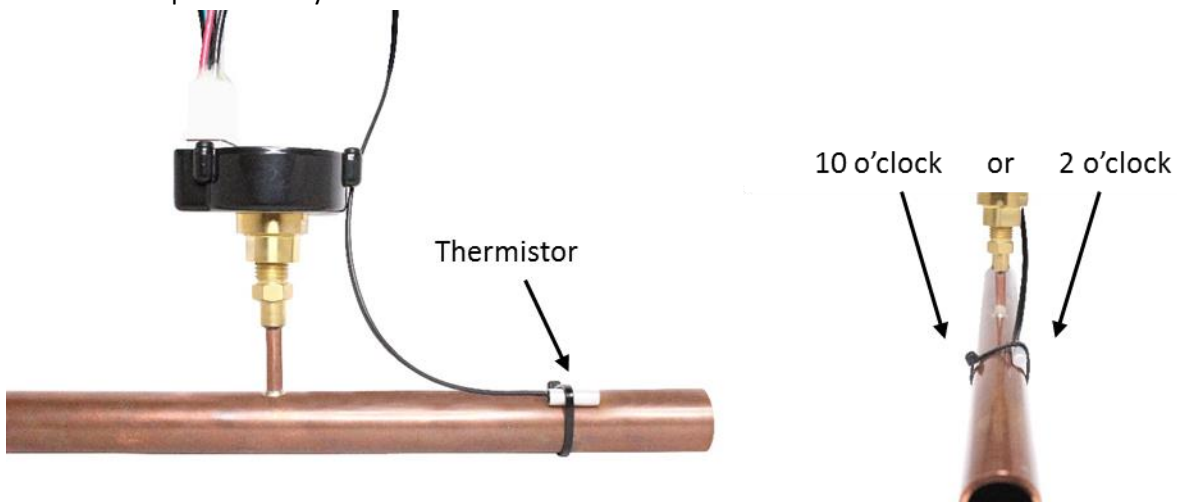

Figure 2-8 Thermistor installation at evaporator outlet



Ensure that the thermistor wire is not tied down to the tubing. The zip tie should only be tied around the thermistor body.



Apply thermal grease between the thermistor and the copper line to obtain the most accurate temperature readings.

- 11.** Wrap the thermistor with the insulation material and secure the insulation in place using a zip tie. The final result should be similar to what is shown below in **Figure 2-9**.

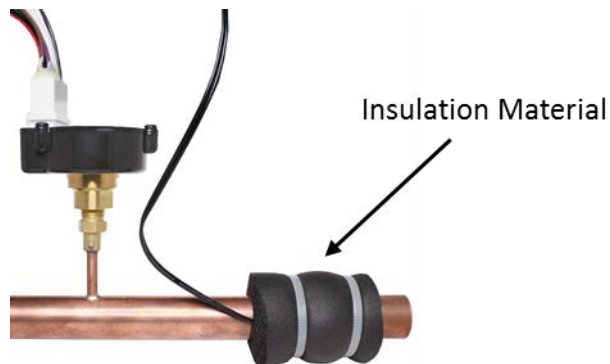

Figure 2-9 Insulation secured to the thermistor

- 12.** Check for leaks at all the braze joints after brazing.
- 13.** Pull a vacuum on the system until 250 microns is reached.
- 14.** Restore refrigerant to the system.
- 15.** Perform another check for leaks at all braze joints.
- 16.** Refer to **Section 3 (Electrical Wiring)** to complete the electrical wiring of the system.

17. Refer to **USHX Software User Interface Manual** to set up communications between the USHX and the computer.
18. Supply power to the USHX with a power supply and power it on.
19. Ensure that the settings in the GUI meet the system requirements (i.e. double check the **Refrigerant, Target Superheat, Device Mode**, and other settings).
20. Power on the HVAC/R system and the MSEV series valve and USHX will automatically begin functioning.
21. Observe the superheat temperature values in the GUI Status tab to ensure that the system is performing nominally. Adjust the system settings through the GUI if necessary.

3 Electrical Wiring

After the mechanical installation of the MSEV series valve(s) and/or USHX(s) into the system, complete the electrical wiring of the system by completing the following steps. Refer directly **Section 3.2** to if more than one unit was installed.

3.1 Single USHC and MSEV Series Valve or Single USHS



Do NOT turn the power source ON until all electrical wiring setup is complete.

1. Check the voltage type (either 12V or 24V) of the MSEV series valve. It can be found on the MSEV series valve model number label. The power source required will be based on the MSEV series valve voltage type.



Ensure that the power source voltage matches the MSEV series voltage type. If a 12V MSEV series valve is powered by a 24V power source, the valve will fail due to an over-voltage. If a 24V MSEV series valve is powered by a 12V power source, the valve will not fully open due to an under-voltage.

2. Obtain a **Class 2** 24 VAC transformer with a capacity of 40 to 100 VA and an output of 24 VAC at a frequency of 60 Hz. Alternatively, a 120 VAC to 12 VDC or 120 VAC to 24 VDC **Class 2** step-down power supply with a 40 to 100 W power rating may be used. The schematics of the power sources are shown below in **Figure 3-1**.



For the user's own safety, **only** Class 2 power sources should be used to power the MSEV series valve and USHX devices.

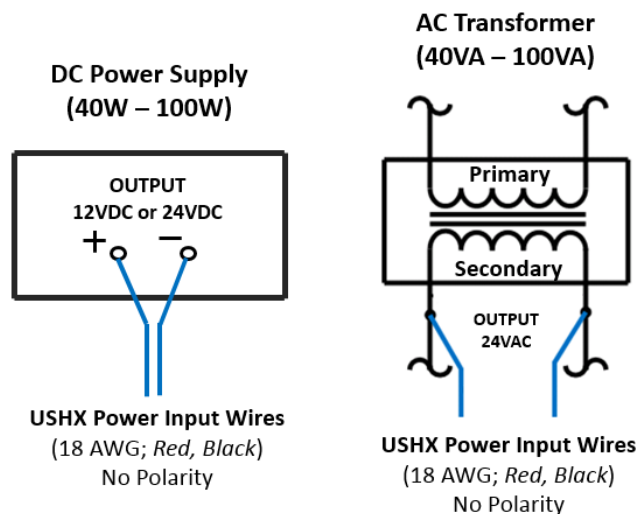

Figure 3-1 Class 2 DC and AC power sources

3. Double check the power source output voltage (AC transformer secondary or DC power supply output).



The reading should be at or near 12VDC, 24VDC, or 24VAC depending on the MSEV series valve and power source. When supplying 24V, the voltage must be within the range of 20.4V to 27.6V. When supplying 12V, the voltage must be within the range of 10.2V to 13.8V.

4. Once the power source output voltage has been identified and checked to be accurate, ensure that the power supply is off before continuing with the steps below.
5. The power input wires (18 AWG red/black wires) on the wiring harness should be connected to the power source as shown below in **Figure 3-2**.



The USHX power input wires are non-polar, so the wire ordering and colors are not significant for the purposes of this step in the procedure. All connectors used between the USHX, power source, and a MSEV series valve should be UL-approved.



The wiring schemes of the 'Single USHC and MSEV series valve' and 'Single USHS Setup' are the same except that the PWM output wires of the USHS for the 'Single USHS Setup' process should be disconnected, terminated with wire nuts, and wrapped with electrical tape so that they do not form short circuits with each other or any other wires or metal surfaces. As for the 'Single USHC and MSEV series valve Setup' process, the PWM output wires should be connected to the MSEV series valve as shown below in **Figure 3-2**.

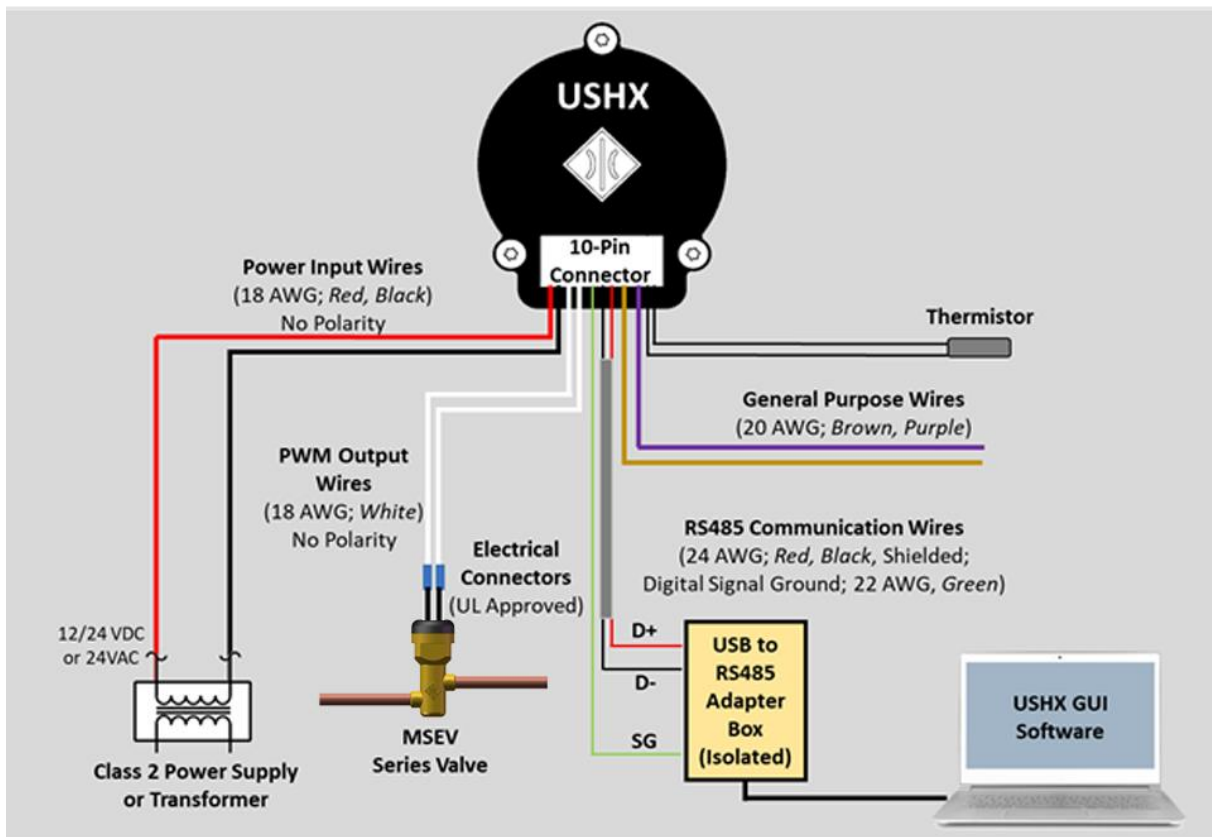

Figure 3-2: Single USHC and MSEV series valve wiring diagram

6. Connect the RS485 communication wires (2-wire gray cord that contains a red and a black wire and the green data ground wire) to the D+, D-, and SG terminals on the USB-to-RS485 converter as shown below in **Figure 3-3**. For the USHX setup, the RS485 will require an adapter with built-in **electrical isolation**.

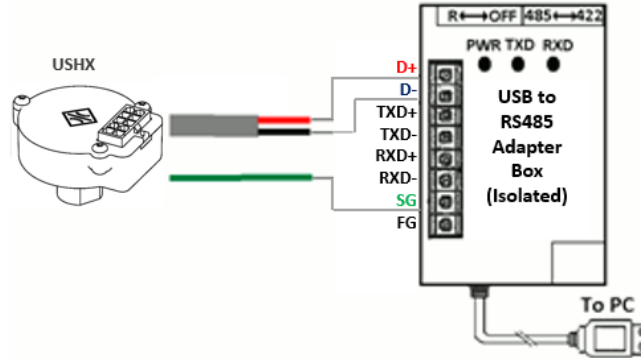

Figure 3-3 USHX-to-RS485 converter connection

7. Connect the RS485 adapter box to the computer via a USB port.
8. Connect the PWM output wires (two 18 AWG white wires) to the MSEV/HC-MSEV/VHC-MSEV electrical connections. These wires are non-polar.
9. The general purpose wires (20 AWG brown/purple wires) must remain unconnected, be terminated with wire nuts, and wrapped with electrical tape so they do not form short circuits with each other or any other wires or metal surfaces.
10. Tape any dangling wires to existing structures such as copper and water lines with at least 4-5 sections of electrical tape each. Use zip ties on top of the electrical tape in a neat and organized manner to further secure the wires.



Ensure that all cables are distanced from fans, high voltage wires (120-208 VAC), and potential areas of water. Ensure that any bare cable leads are covered with electrical tape and do not touch other wire leads or any metal structures.

11. The electrical wiring for Single USHC and MSEV/HC-MSEV/VHC-MSEV or Single USHS setup is now complete.

3.2 Multiple USHCs and MSEV Series Valves or Multiple USHSs



Do NOT turn the power source ON until all electrical wiring setup is complete.

1. Check the voltage type (either 12V or 24V) of the MSEV series valves. It can be found on the MSEV series valve model number label. The power source required will be based on the MSEV series valve voltage type.



Ensure that the power source voltage matches the MSEV series valve voltage type. If a 12V MSEV series valve is powered by a 24V power source, the valve will fail due to

an over-voltage. If a 24V MSEV series valve is powered by a 12V power source, the valve will not fully open due to an under-voltage.

2. Obtain a **Class 2** 24 VAC transformer with a capacity of 40 to 100 VA and an output of 24 VAC at a frequency of 60 Hz. Alternatively, a 120 VAC to 12 VDC or 120 VAC to 24 VDC **Class 2** step-down power supply with a 40 to 100 W power rating may be used. The schematics of the power sources are shown below in **Figure 3-4**. See **Table 3-1** below to determine what minimum capacity/power rating requirements must be met with these power sources based on the number of MSEV series valves installed.



For the user's own safety, **only** Class 2 power sources should be used to power the MSEV series valves and USHX devices.

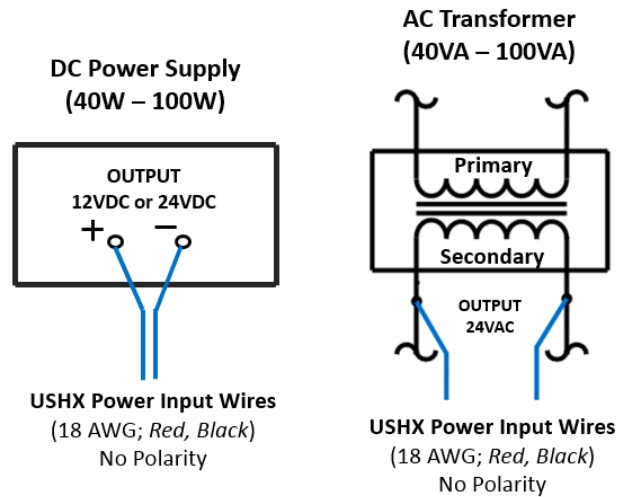

Figure 3-4 Class 2 AC and DC power sources

Table 3-1: AC Transformer Minimum Capacity and DC Power Supply Minimum Power Rating Required Based on Number of MSEV series valves Installed

| MSEV Series Valve Voltage Type | Number of MSEV series valves per Power Source (Maximum 6) | AC Transformer Minimum Capacity Required (Volt-Amps) | DC Power Supply Minimum Power Rating Required (Watts) |
|--------------------------------|---|--|---|
| 12V or 24V | 1 | 40 VA | 40 W |
| | 2 | 50 VA | 50 W |
| | 3 | 60 VA | 60 W |
| | 4 | 70 VA | 70 W |
| | 5 | 80 VA | 80 W |
| | 6 | 100 VA | 100 W |

3. Install the transformer or power supply at the center of the all the USHXs.



The below wiring methodology is recommended so that the load of the controllers on either end of the transformer will be the same.

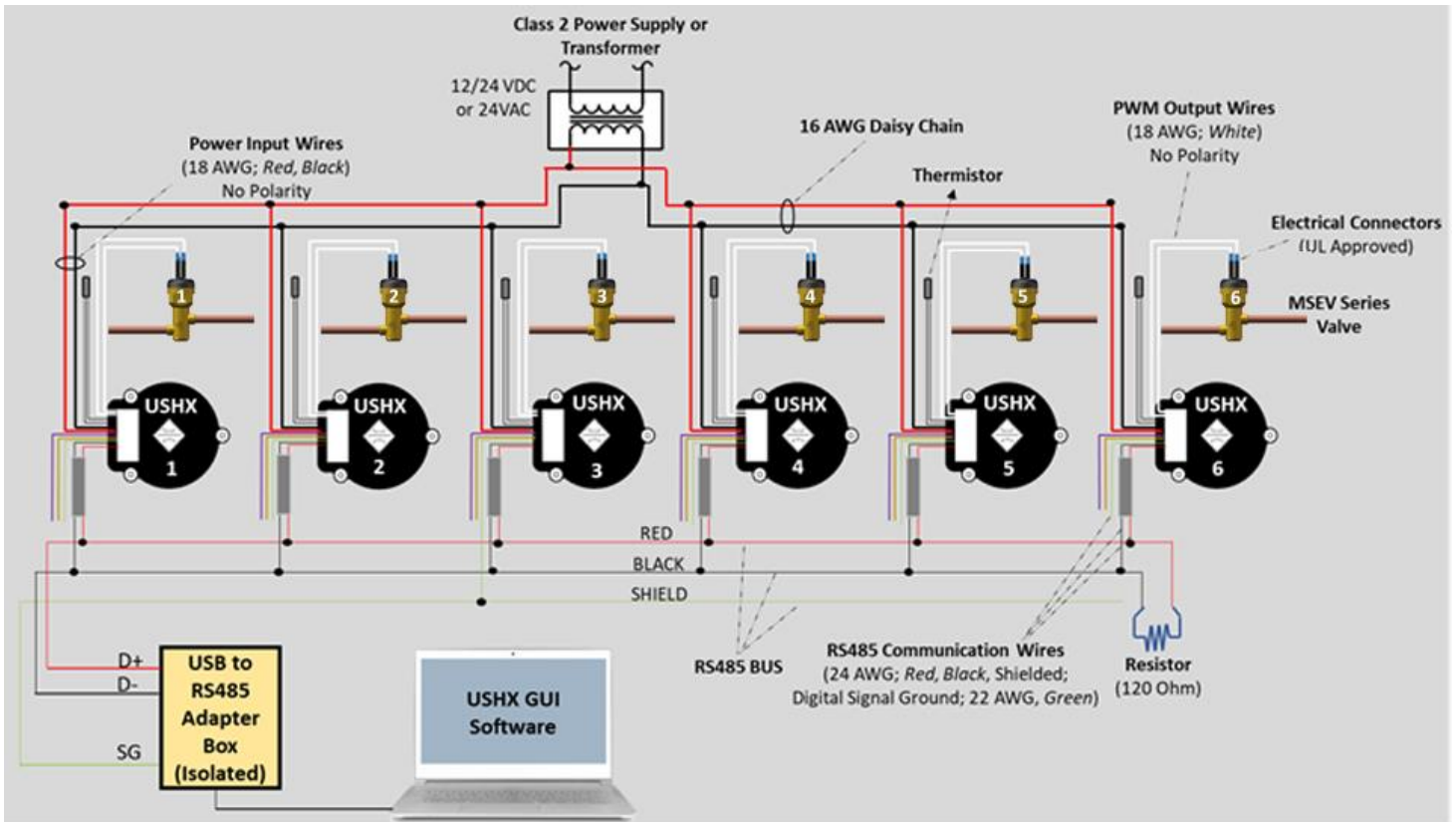

Figure 3-5 Multiple USHCs and MSEV series valves networking diagram

The wiring schemes of the ‘Multiple USHCs and MSEV Series Valves’ setup and ‘Multiple USHSS’ setup are the same except that the PWM output wires of each USHS for the ‘Multiple USHSS’ setup process should be disconnected, terminated with wire nuts, and wrapped with electrical tape so that they do not form short circuits with each other or any other wires or metal surfaces. As for the ‘Multiple USHCs with Multiple MSEV Series Valves’ setup process, the PWM output wires should be connected to the valves as shown in **Figure 3-5**.

4. Double check the power source output voltage (AC transformer secondary or DC power supply output).



The reading should be at or near 12VDC, 24VDC, or 24VAC depending on the MSEV series valve and power source. When supplying 24V, the voltage must be within the range of 20.4V to 27.6V. When supplying 12V, the voltage must be within the range of 10.2V to 13.8V. Do **NOT** Earth-ground the power source output.

5. Once the power source output voltage has been identified and checked to be accurate, ensure that the power supply is off before continuing with the steps below.

- Form a daisy chain with the power lines by connecting the USHX power input cables (18 AWG red/black wires) that are closest to the transformer on either side (USHX 3 and 4), as shown in **Figure 3-5**. Use 16 AWG stranded copper wire for extensions.



The USHX power input wires are non-polar, so the wire ordering and colors are not significant for the purposes of this step in the procedure. All connectors used between the USHX, power source, and MSEV series valve should be UL approved. If the USHX power input wires do not reach the system transformer add 16 AWG extensions to the cables as needed.

- Run the power input wires from USHX 3 to USHX 2 and then from USHX 2 to USHX 1 as shown in **Figure 3-5**.
- Run the power input wires from USHX 4 to USHX 5 and then from USHX 5 to USHX 6.
- The USB-to-RS485 adapter is used for USHX communications. Each USHX wiring harness includes RS485 data communication wires (2-wire gray cord that contains a red and a black wire and the green data ground wire).
- Create a daisy chain for the RS485 BUS as shown in **Figure 3-5**. Connect the gray RS485 communication wire of USHX 1 to USHX 2. Use similar communication cables when extensions are required. Do not connect the data ground wire between USHX 1 and 2. It should remain unconnected and protected with wire nuts and wrapped with electrical tape.
- Similarly connect USHX 2 to USHX3 and then USHX 3 to USHX 4. Repeat this pattern until USHX 6.
- For each transformer, only one USHX data ground wire should be connected to the RS485 adapter signal ground input. As shown above in **Figure 3-5**, only the data signal ground wire (green wire) of USHX 3 is connected to the RS485 adapter signal ground input.
- RS485 allows up to 32 nodes (or USHXs) to be connected on one channel (or daisy chain). **Figure 3-6** below shows an example of three daisy chains of 12 USHXs each.

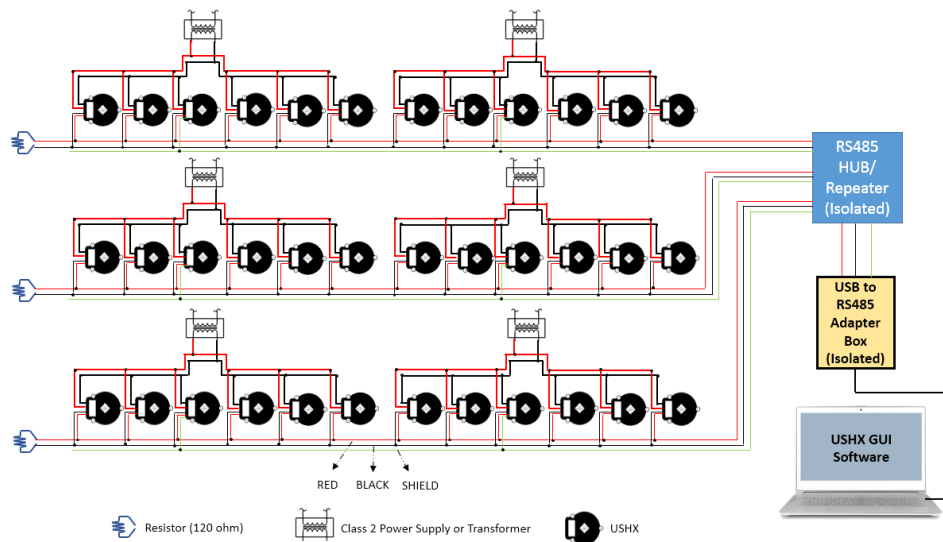

Figure 3-6 Multiple USHXs-to-RS485 hub/repeater networking

14. At the end of each daisy chain, install a 120 Ω termination resistor, as shown in **Figure 3-6**.
15. Procure an isolated RS485 hub/repeater. If an isolated hub/repeater cannot be found, then it is necessary to install an isolator for each channel.



The communication cable must be kept away from high-strength electric and magnetic fields such as those emitted from USHX and MSEV series valve power wires, 110/220 VAC wires, fan motors, relay coils, etc.

The exposed metal on the ground wires of the remaining controllers should be covered with electrical tape.

16. Connect the isolated RS hub/repeater to the isolated RS485 adapter box. Connect the box to the computer via a USB port.
17. Connect the two PWM output wires (two 18 AWG white wires) of each USHX to the electrical connections of corresponding MSEV series valve. These wires are non-polar.
18. Additional general purpose wires (20 AWG brown/purple wires), if they exist on the harness, must remain unconnected, be terminated using wire nuts, and wrapped with electrical tape so that they do not form short circuits with each other or any other wires or metal surfaces.
19. Tape any dangling wires to existing structures such as copper and water lines with at least 4-5 sections of electrical tape each. Use zip ties on top of the electrical tape in a neat and organized manner to further secure the wires.



Ensure that all cables are distanced from fans, high voltage wires (120-208 VAC), and potential areas of water. Ensure that any bare cable leads are covered with electrical tape and do not touch other wire leads or any metal structures.

20. The electrical wiring for Multiple USHCs and MSEV series valves or Multiple USHSs is now complete.
21. Refer back to **Section 2.2 (Installing the USHX), Step 17** and complete the remaining steps to finalize the hardware installation process.

4 Troubleshooting

The following section describes troubleshooting procedures for the USHX and MSEV series valve. If the system is running abnormally, first check the wiring for broken or shorted connections. Repair broken wires and remove short circuits between touching wires or between wires and any metal surfaces. If there are no wiring problems, then use the following table to further diagnose the problem (**assuming everything else in the system such as the compressor, evaporator, filter drier, etc. is working properly**).

| Problem | Possible Cause | Action |
|--|---|---|
| <p>High Superheat:</p> <p><i>This may indicate that the MSEV series valve is not fully opening. Common symptoms include compressor short cycling.</i></p> | Inadequate Power to the Valve | Check the power source voltage. The voltage leaving the transformer and entering the USHX should be close to the intended supply voltage (24V or 12V). If the transformer voltage is too low, there is a problem with the transformer or its wiring. If the voltage entering the USHX is low and the transformer voltage is normal, there is a problem with the terminal connections or interconnecting wiring to the USHX. |
| | Temperature Sensor Incorrectly Mounted | Check the mounting of the USHC temperature sensor. The sensor should be firmly mounted to the outlet of the evaporator at a 10 o'clock or 2 o'clock position. Check that the temperature sensor is wrapped with insulated tape. |
| | Over Voltage to the MSEV Series Valve | Check the resistance across the valve terminals. Remove both power connections from the MSEV series valve and measure its resistance with a multimeter. The resistance reading should be between 26-34Ω for a 24V valve and between 6-13Ω for a 12V valve. If the resistance is significantly out of this range (or zero), the MSEV series valve is damaged and should be replaced. |
| | MSEV Series Valve Slow to Open | Check that the USHX Gain settings meet the system requirements. (Also applicable if the MSEV series valve opens too quickly.) Connect and disconnect the power to the valve several times to manually actuate the valve. |
| <p>Low Superheat:</p> <p><i>This may indicate that the MSEV series valve is staying open. Common symptoms include compressor frosting.</i></p> | MSEV Series Valve Slow to Close | Check that the USHX Gain settings meet the system requirements. (Also applicable if the MSEV series valve closes too quickly.) Connect and disconnect the power to the valve several times to manually actuate the valve. |
| | Temperature Sensor Incorrectly Mounted | Check the mounting of the USHC temperature sensor. The sensor should be firmly mounted to the outlet of the evaporator at a 10 o'clock or 2 o'clock position. Check that the temperature sensor is wrapped with insulated tape. |
| | Severely Oversized Valve | Determine the capacity of the evaporator and check the valve model number to confirm that the two are compatible regarding their capacities. |
| | | |