

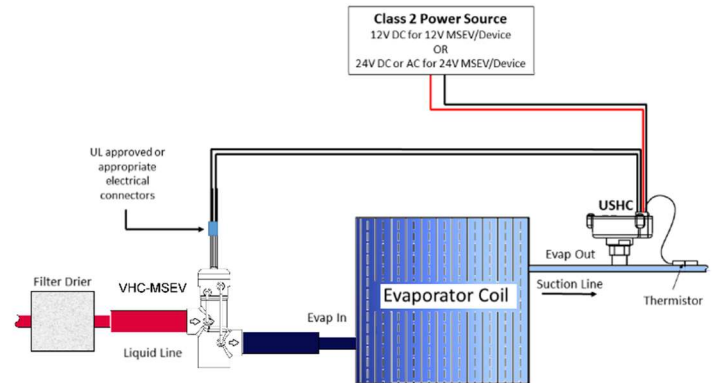

Introduction

The Very High Capacity Modular Silicon Expansion Valve (VHC-MSEV) is an electronically controlled, normally closed and one directional flow valve. It can be used for refrigerant mass flow control for today's industry-standard HVAC and Refrigeration systems. The VHC-MSEV provides precise superheat control and quick mass flow adjustments through a closed loop control methodology achieved with DMQ's Universal SuperHeat Controller (USHC). Embedded with the silQflo® Silicon Servo Valve (SSV), the VHC-MSEV is the fastest responding refrigerant expansion valve in the industry.



Principle of Operation

The VHC-MSEV is a two-stage proportional control valve. The first stage silQflo® SSV microvalve acts as a pilot valve that controls the second stage spool valve. When the microvalve receives a PWM signal, it modulates to change the pressure differential across the second stage spool valve. The spool will move to balance the pressure differential, effectively changing the orifice opening of the valve to control the desired amount of refrigerant flow. The maximum effective orifice allowed by the spool in the complete open position defines the maximum valve cooling capacity. The VHC-MSEV comes in a single footprint that accommodates different spool cartridges to cater to various valve capacity.

Features and Benefits

- Fast response
- Precise superheat control
- Single Footprint for all capacities
- High Durability and Reliability
- Closed Loop Control
- Cost Effective Electronic Control

Applications

Industrial Chillers, Commercial Cooling, Transport Refrigeration, etc.

Technical Specifications

Suitable Environmental Temperature	-40°F ~ 158°F (-40°C ~ 70°C)
Suitable Fluid Temperature	-40°F ~ 158°F (-40°C ~ 70°C)
Suitable Environmental Humidity	< 95% RH
Voltage Input	12V _{rms} ±20% (for a 12V valve) or 24V _{rms} ±20% (for a 24V valve) Pulse Width Modulated 0 - 100%, 15 – 200 Hertz
Power Consumption	Max power 10±1W, Nominal 5±1 W t _{operating} ≥ 0.5 S
Response Time	500 ms (from fully close to fully open)
Minimum Operating Pressure Differential	25 psi (0.17 MPa)
Maximum Operating Pressure Differential	500 psi (3.45 MPa)
Proof Pressure	700 psi (4.83 MPa)
Burst Pressure	3500 psi (24.13 MPa)
Refrigerant Compatibility	R410A, R404A, R134A, R22 (call for all other refrigerants)
Refrigerant Oil Compatibility	Polyolester (POE); Polyalkylene Glycol (PAG); Mineral Oil (MO); Polyvinylether (PVE)
Electrical Connections	Two 20 AWG, UL 1332 wires with minimum length of 6 inches (152mm)
Weight	Approx. 24.7oz (700 grams)
Filtration requirement per ISO 4406:1999 Standard	20/19/16 or better
Product Listing and Certifications	UL 429, cUL, IP67



Model Number Nomenclature

AXXV-C6XXX

12V = 12 Volts
24V = 24 Volts

Capacity Code

Nominal Capacity Tables

MSEV Model Number	R410A		R22		R404A		R134A	
	Nominal, Ton	Capacity, Ton (kW)	Nominal, Ton	Capacity, Ton (kW)	Nominal, Ton	Capacity, Ton (kW)	Nominal, Ton	Capacity, Ton (kW)
AXXV-C6612	30	35.4 (124.5)	25	29.9 (105.2)	17	21.5 (75.5)	19	23.5 (82.5)
AXXV-C6650	35	39.3 (138.2)	28	33.2 (116.8)	19	23.8 (83.8)	21	26.0 (91.6)
AXXV-C6715	40	45.9 (161.4)	34	38.8 (136.4)	23	27.8 (97.9)	25	30.4 (106.9)
AXXV-C6773	45	51.7 (181.8)	38	43.7 (153.6)	26	31.3 (110.2)	29	34.3 (120.5)
AXXV-C6799	50	54.3 (191.0)	41	45.9 (161.3)	28	32.9 (115.8)	31	36.0 (126.5)

The capacity tables for each refrigerant type is based on vapor free, 100 °F liquid refrigerant entering the expansion valve, a superheat of 4 °F, and the evaporator temperature at 40 °F. Please call for more information on valve capacity and sizing.

Physical Dimension and Product Markings

